

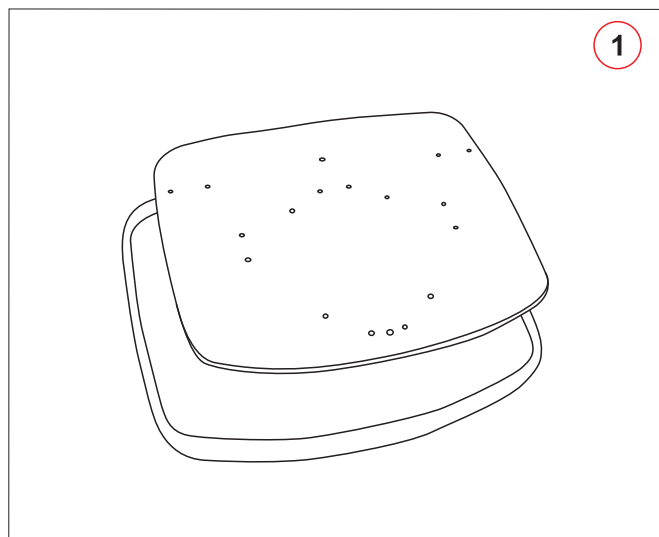

# Montagem

## Maxxer

(giratória)



1 - Colar a espuma na madeira.

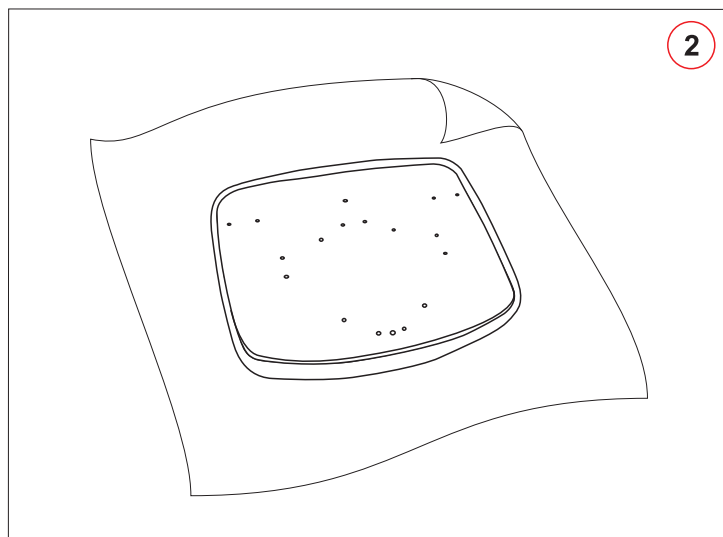

2 - Colar o tecido na espuma e grampear na madeira do assento.

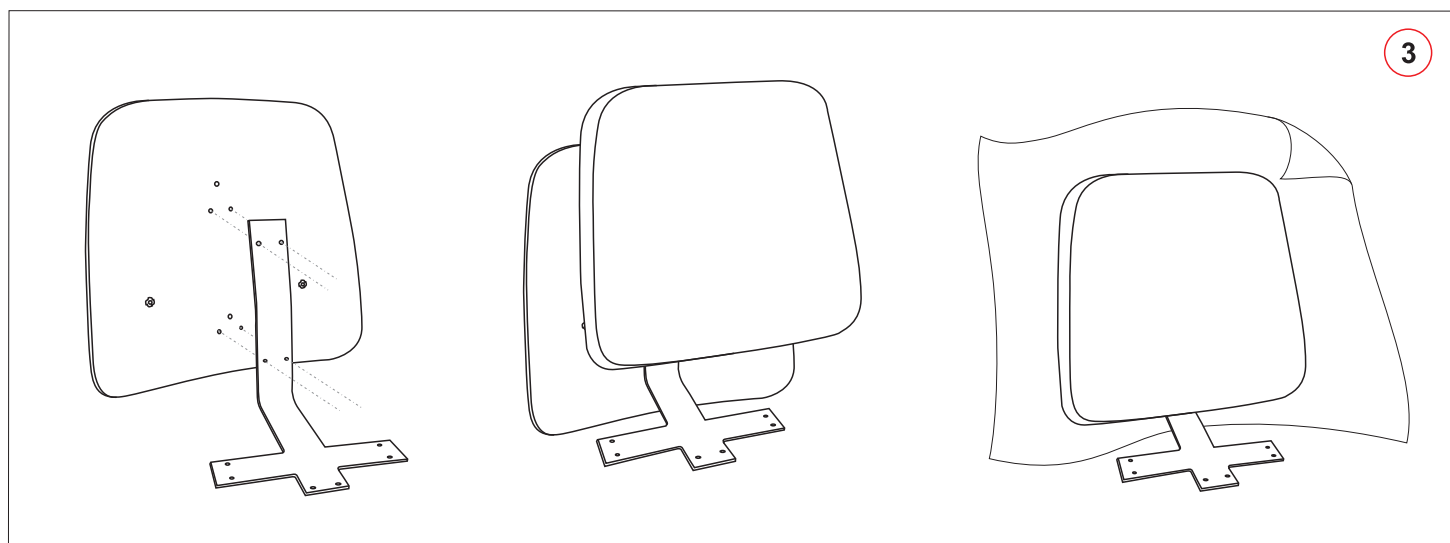

3 - Fixar a lâmina na madeira do encosto utilizando 4 parafusos PH PAN M6X30mm, em seguida colar a espuma na madeira e realizar a tapeçaria do encosto.

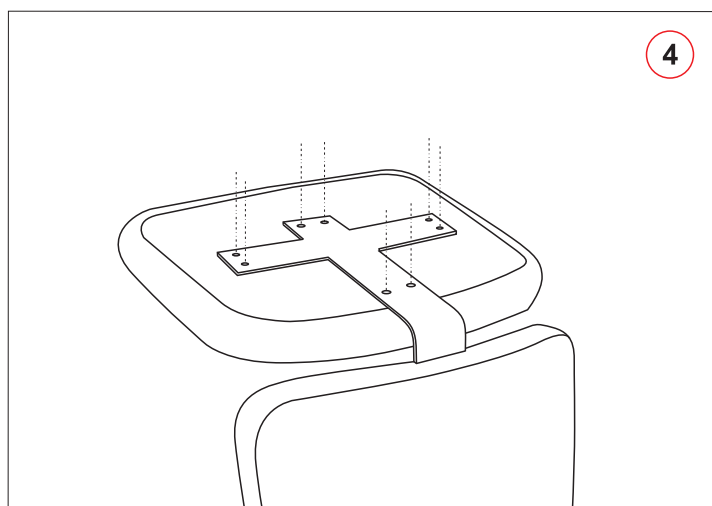

4 - Fixa a lâmina no assento tapeçado com 8 parafusos PH CHATO M6 X 30mm.

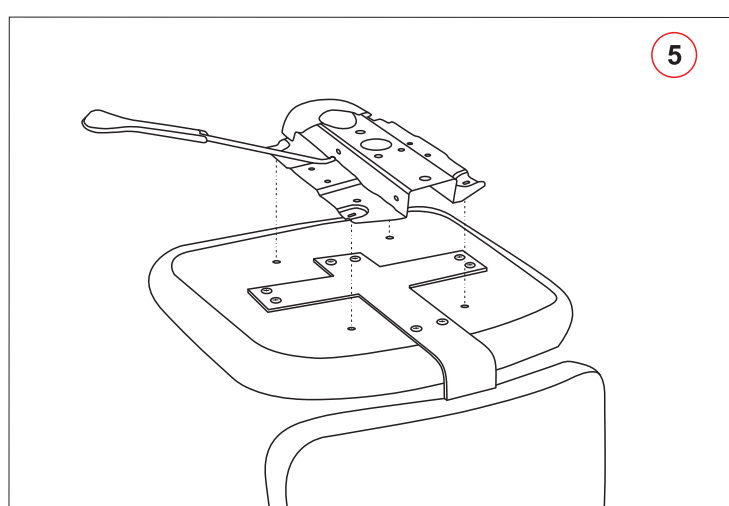

5 - Localizar no assento tapeçado os furos para fixação do mecanismo, em seguida fixar o mesmo com 4 parafusos PH PAN M6X40mm.

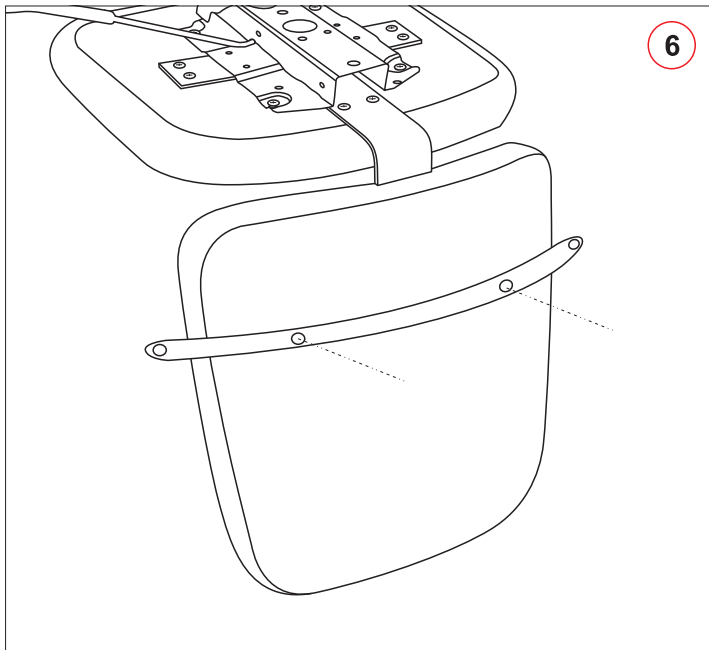

6 - Fixar o suporte do encosto com 2 parafusos PHL CH M6X35mm.

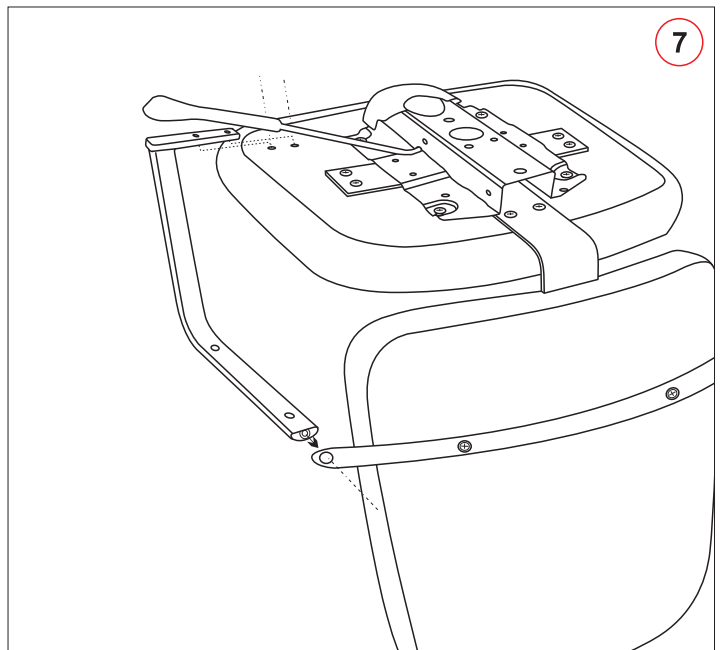

7 - Fixar cada braço iniciando a fixação pelo suporte do encosto com 1 parafuso ALL M8X20mm e posteriormente fixar o outro lado do braço no assento, utilizando 2 parafusos PH PAN M6x40mm.

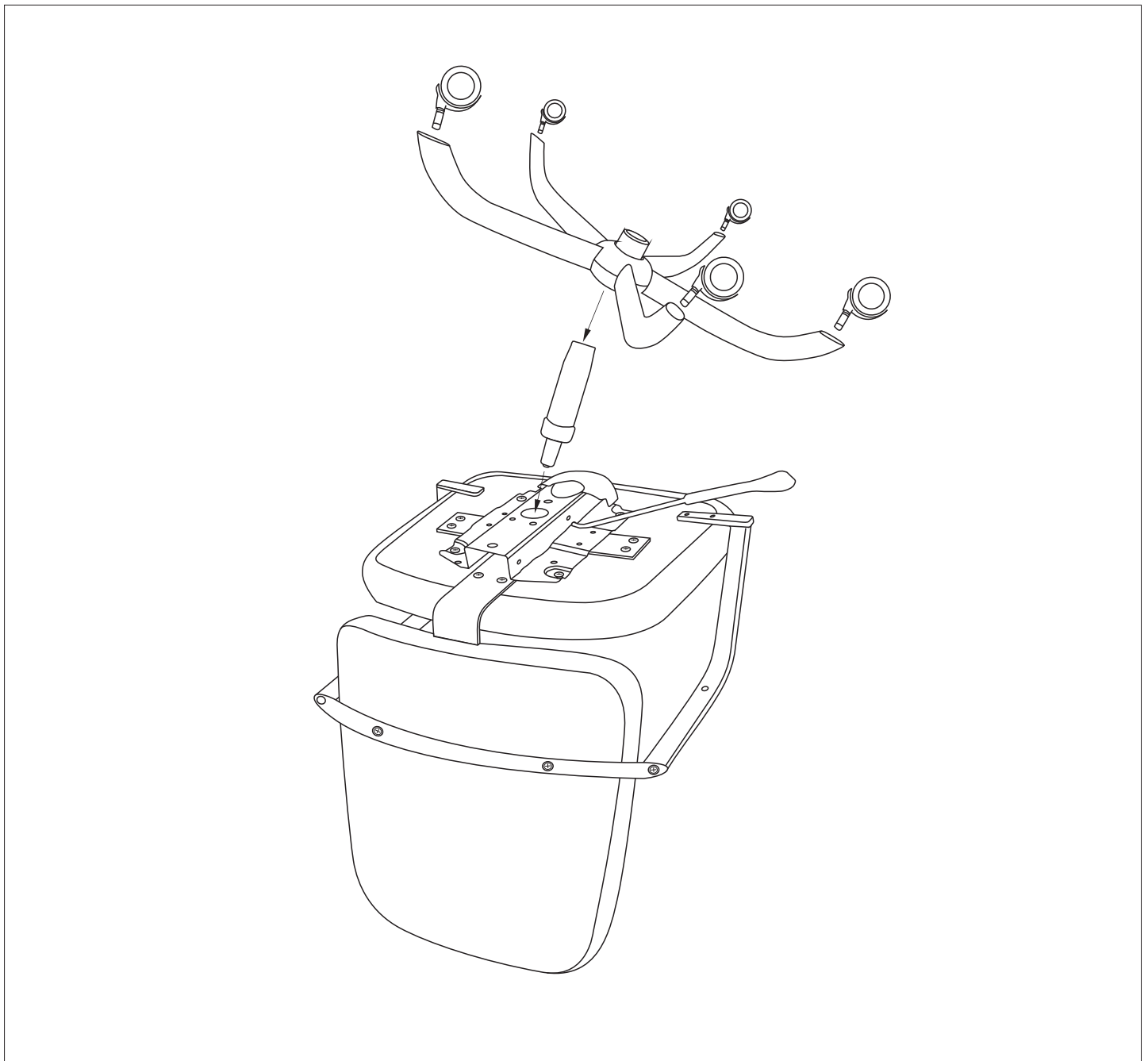

8 - Encaixar o pistão, a estrela e os rodízios conforme figura.